

- Microwave Technologies
- Custom Technical Ceramics
- Industrial Services
- Quality Assurance, NQA - 1

Standard 99.8% Alumina Kiln Nails and Washers

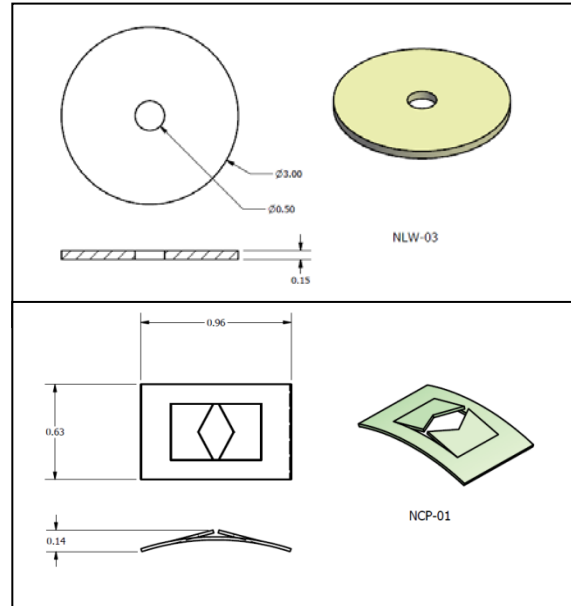
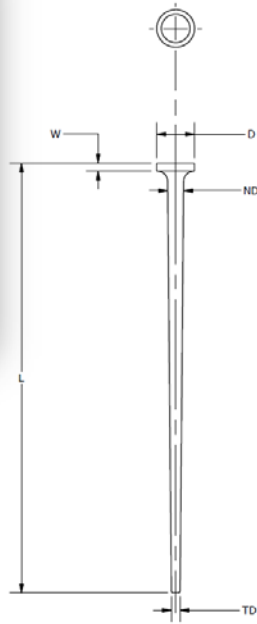

Nail Part Number	Description	Material	D(in)	L	W	ND	TD	Price (each)
NL-06	6" Nail	99.8% Alumina	0.85"	6.5"	0.2	0.4	0.25	\$14.49
NL-09	9" Nail	99.8% Alumina	0.85"	9.5"	0.2	0.4	0.20	\$17.05
NL-11	11" Nail	99.8% Alumina	0.85"	11.2"	0.2	0.4	0.15	\$18.40

Extras Part Number	Description	Material	OD	ID	t	Price (each)
NLW-03	Nail Washer (6" ,9" & 11")	99.8% Alumina	3.00"	0.5"	0.15"	\$10.45
NSP-01	Nail Spring	Steel	--	--	--	\$0.50
NCP-01	Nail Clip	Steel (Green)	--	--	--	\$0.50

Notes: Standard tolerances are +/- 4% on all dimensions UOS. Tighter tolerances and custom sizes are available upon request.

Please call or e-mail us at custserv@hadrontechnologies.com for pricing or inquiries about custom sizes and materials.